

## University of South Florida *Energy Delivery Infrastructures*

**PI:** Lee Stefanakos   **Co-PIs:** Zhixin Miao

**Students:** L. Piyasinghe (Ph.D.), L. Xu (Ph.D.), M. Alhaider (Ph.D.)

**Description:** The purpose of the project is to simulate the effects of a renewable energy generation system (renewable energy distributed generation and a battery system), in a micro-grid, on the distribution grid system during critical conditions such as power peaks. Existing simulation tools can be used to properly represent dynamic and transient behaviors of microgrids.

**Budget:** \$485,184

**Universities:** USF

### Project Summary

This project report summarizes three on-going tasks: 1) Microgrid power management scheme analysis; 2) Control and operation of a battery system in a microgrid; and 3) Impacts of pulse power loads on a microgrid.

*Microgrid power management scheme analysis:* With the increasing use of renewable energy resources and energy storage devices, inverter-based distributed energy resources (DERs) become the important components in microgrids. As diesel generators with direct ac connections are the current most cost effective and reliable power sources, the stability investigation of microgrids should include both types of DERs. In this project, dynamics of diesel generation are included and the interaction of the diesel generators and the inverter-based DERs will be investigated using eigenvalue analyses and time-domain simulations. The significant contributions of this research include: 1) identification of the stability problem in microgrids with inverter-based DERs and conventional generators, and 2) investigation of the interaction problem of inverter-based DERs and conventional generators in islanded microgrids..

*Control and operation of a battery system in a microgrid:* the objective of this task is to investigate the control strategies of a Li-Ion battery group with a PV array within a microgrid. At the grid-connected mode, the battery and the PV array operate at power control mode, while at the autonomous mode the battery provides voltage and frequency control instead. The contributions of this work include: (i) a detailed model of a battery pack, including state of charge (SOC), short-time and long-time transient characteristics and a detailed model of a PV array have been built; and (ii) effective control strategies for a battery with the PV array system to operate at both the grid-connected and the autonomous modes have been developed. A test microgrid consisting of a voltage source converter (VSC) interfaced battery, a PV array, passive loads and an induction machine is built in PSCAD/EMTDC. Simulations have been carried out and demonstrate that the proposed control strategies could coordinate independent distributed generation effectively..

*Impacts of pulse power loads on a microgrid:* the main objective of this task is to investigate the pulse power load (PPL) impact on the stability of a microgrid with power electronic converters. The PPLs are largely employed in areas of high power radars, lasers, high energy physics experiments and weapon systems such as rail guns. The peak power of a pulse load can vary from several hundred kilowatts to several hundred megawatts and the time duration is typically from microseconds to seconds. Hence for the proposed work, a microgrid with Voltage Source Converter (VSC) based inverters and synchronous generators are considered in order to provide a better approach towards the smart grid. The study is conducted in PSCAD/EMTDC and Matlab/SimPowersystems.

## Microgrid power management scheme analysis

Stability analysis of a microgrid is carried out in [1]. The system consists of diesel generators with direct ac connections, which are the current most cost effective and reliable power sources, and VSC converter interfaced DERs. Those DERs could be fuel cells. Stability investigation for the hybrid systems has not been addressed in the previous literature. The research work models the dynamics of diesel generation and converter control loops in a da reference frame. The interaction of the diesel generators and the inverter-based DERs is investigated using eigenvalue analysis and time-domain simulations. The significant contributions of [1] include: (i) identification of the stability problem in microgrids with both inverter-based DERs and conventional generators and (ii) investigation of the interaction problem of inverter-based DERs and conventional generators in islanded microgrids.

The study system is shown in Fig. 1. The system is built based on the benchmark system of IEEE standard 399-1997. Two diesel engine generators and two converter-interfaced DERs form a microgrid. Under islanded conditions, the breaker connected to the utility is open.

### Effect of f-P droop on dominating system modes

The root locus of a changing  $f - P$  droop gain in one of the inverter-based DERs is shown in Fig. 2. From the root locus diagram in Fig. 2, it is found that the gain of the  $f - P$  droops in the inverter-based DERs do not impact the system stability significantly. Rather, the gain of the  $f - P$  droop in the diesel engine impacts system stability significantly. A larger gain means more participation in load sharing. In Fig. 2, it is noted that the larger the gain, or the more the diesel engines participate into load sharing, the more unstable the microgrid becomes. Therefore, the diesel generators should have a limited gain. This results in an insignificant participation in load sharing. Fig. 3 shows the dynamic response of the four DERs due to a load change. The simulation results corroborates with the analysis.

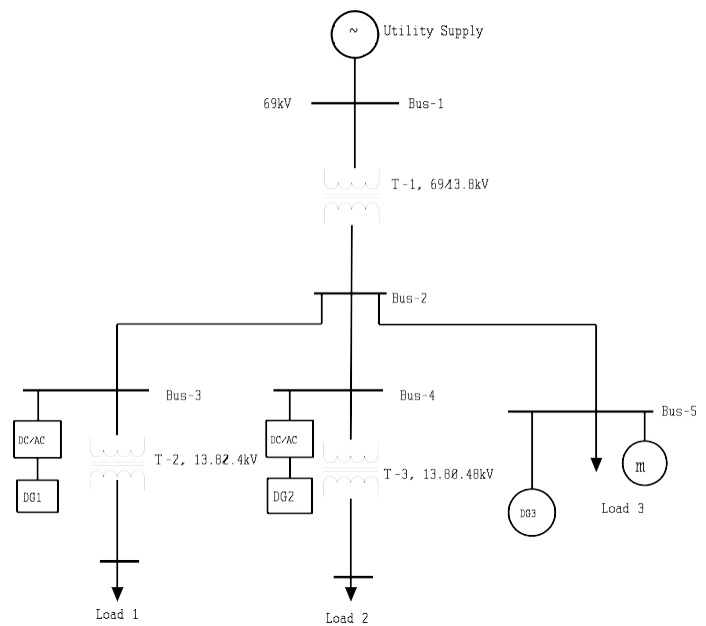

Fig. 1 Study system

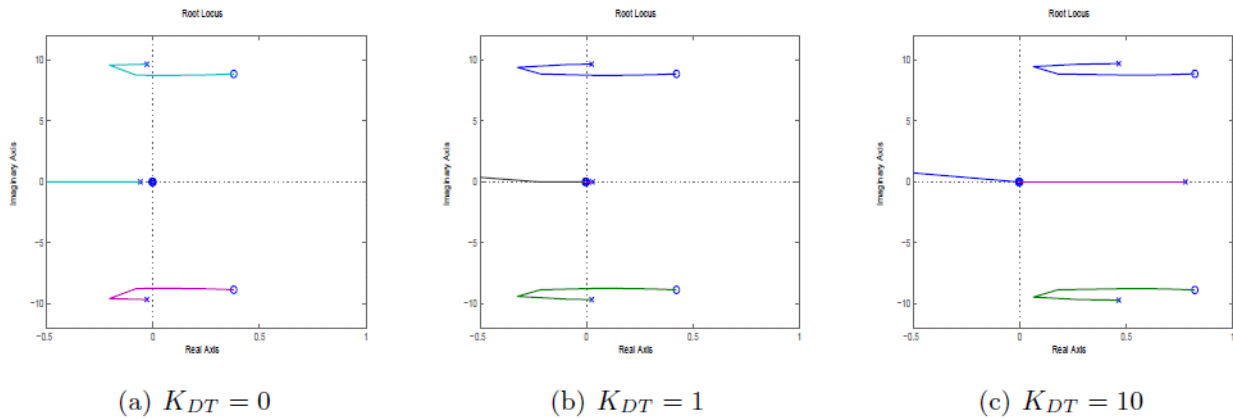

Fig. 2 Root locus diagrams with a changing f-P droop gain in DER3.

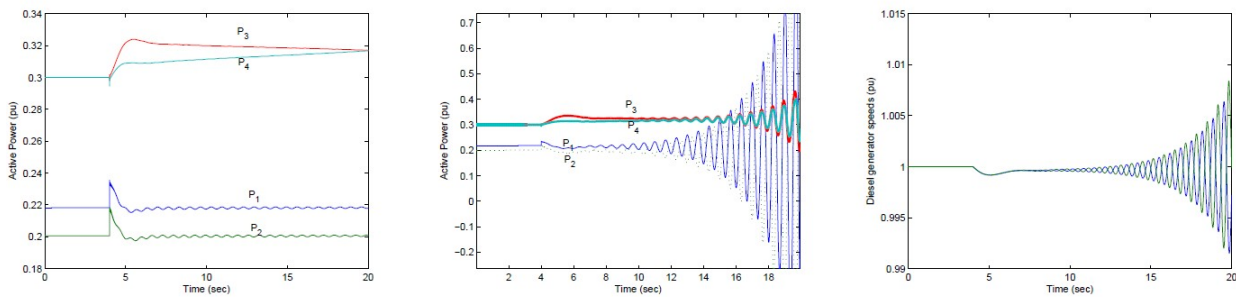

Fig. 3. Dynamic performance of the four DERs due to a load change.

Publications & Conferences

1. Z. Miao, A. Domijan, and L. Fan, "Investigation of Microgrids with Both Inverter Interfaced and Direct AC Connected Distributed Energy Resources," *IEEE Trans. Power Delivery*, vol. 26, no. 3, pp. 1634-1642, July 2011.
2. L. Xu, Z. Miao and L. Fan, "Control of a back-to-back VSC system from grid-connected to islanded mode in microgrids," in *Proc. of IEEE Energy Tech*, May 2011
3. Z. Miao, A. Domijan, and L. Fan, "Negative Sequence Compensation for Unbalance in Distributed Energy Resources Interfacing Inverters," *International Journal of Power and Energy Systems*, no. 3, 2012.
4. L. Fan, Z. Miao, and A. Domijan, "Impact of Unbalanced Grid Conditions on PV Systems," *IEEE Power & Energy Society General Meeting* 2010.

**Control and operation of a battery system in a microgrid.**

The objective of this research is to study the control strategies for a microgrid with both a battery group and a PV array. The study approach is detailed model based simulation. Detailed battery models have been developed both by mathematic equations and electrical circuits. A Li-ion battery model is using electrical components, which was validated through experiments. PV model has been investigated thoroughly in the literature. The current source and anti-parallel diode model has been proved to be able to simulate the V-I characteristics of a solar cell accurately. For the PV and battery combined systems, a power management mechanism that could optimize the power flow. Utilize batteries to reduce the fluctuations of PV output. The power within PV and battery system can be scheduled from the power system's point of view. Besides the PV and battery combined system, PV and capacitor combined system is also examined by other researchers. Capacitors are also could be used to reduce the power fluctuation of PV, or participate in frequency control.

The focus of this task is control strategies at the autonomous mode. We have conducted research on developing battery operating strategies based on a detailed battery model at both the grid-connected and the autonomous mode. The research is expanded to include a PV array in the microgrid. Coordination among different DERs will be taken into consideration.

The microgrid studied in this paper consists of three distributed energy resources (DERs). An induction machine driven by a diesel engine works at the generating mode. It supplies active power to the loads within microgrid. A PV array is connected to the microgrid and supports the loads as well. A VSC interfaced battery station is included to store excess energy from the PV array or inject energy when there is a need. Fig. 4 shows the topology of the investigated microgrid where three distribution lines are used to connect each component. The topology complies with the IEEE Standard 399-1997.

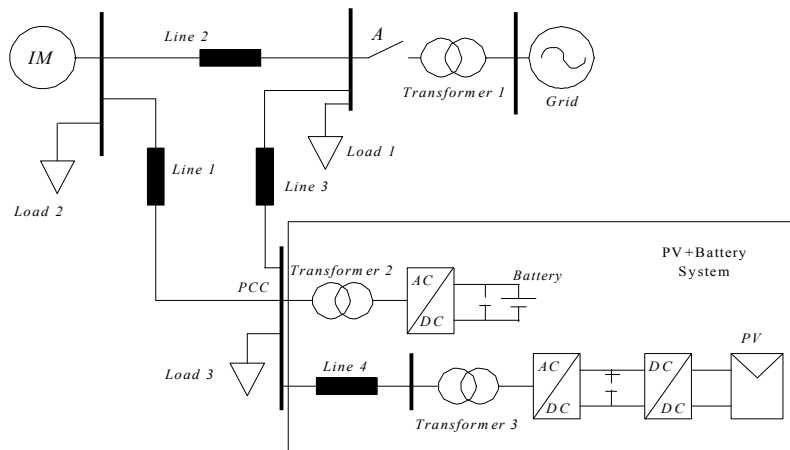

FIGURE 4. STUDY SYSTEM OF TASK 2

Figure 5 shows the power coordination mechanism of the PV and the battery system. The AC grid voltage and frequency are the variables to be controlled. The output real power and reactive power of the battery system are dependent on the measured frequency error and voltage error. The total output power from the PV and the battery should meet the requirements of the microgrid.

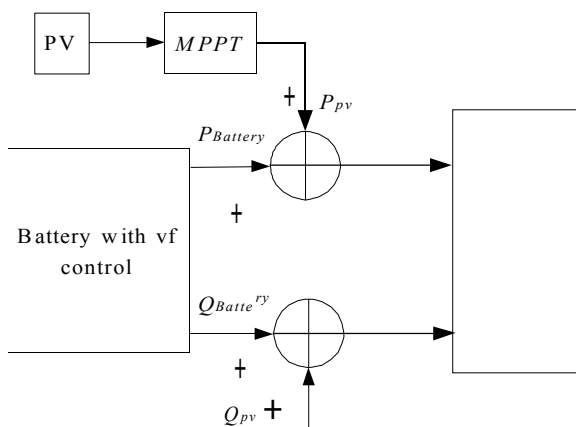

Figure 5. Coordinated control strategy of PV and battery system at autonomous mode in Task 2.

Publications & Conferences

1. L. Xu, Z. Miao and L. Fan, "Control of a battery system to improve operation of a microgrid," IEEE PES General Meeting, 2012.

- L. Xu, Z. Miao and L. Fan, “Coordinated Control of a Solar and Battery System in a Microgrid,” IEEE T&D meeting, 2012.

### Impacts of pulse power loads on a microgrid

The objective is to investigate the pulse power load (PPL) impact on the stability of a microgrid with power electronic converters. The PPLs are largely employed in areas of high power radars, lasers, high energy physics experiments and weapon systems such as rail guns. The peak power of a pulse load can vary from several hundred kilowatts to several hundred megawatts and the time duration is typically from microseconds to seconds. Hence for the proposed work, a microgrid with Voltage Source Converter (VSC) based inverters and synchronous generators are considered in order to provide better approach towards the smart grid. The study is conducted in PSCAD/EMTDC and Matlab/SimPowersystems.

The reported work considers the impact of a PPL load on system voltage profile only. But for the proposed Task 3, the impact on both voltage and the frequency of the microgrid system is considered. The study of the microgrid system to evaluate the impacts of PPL is shown in Fig. 6.

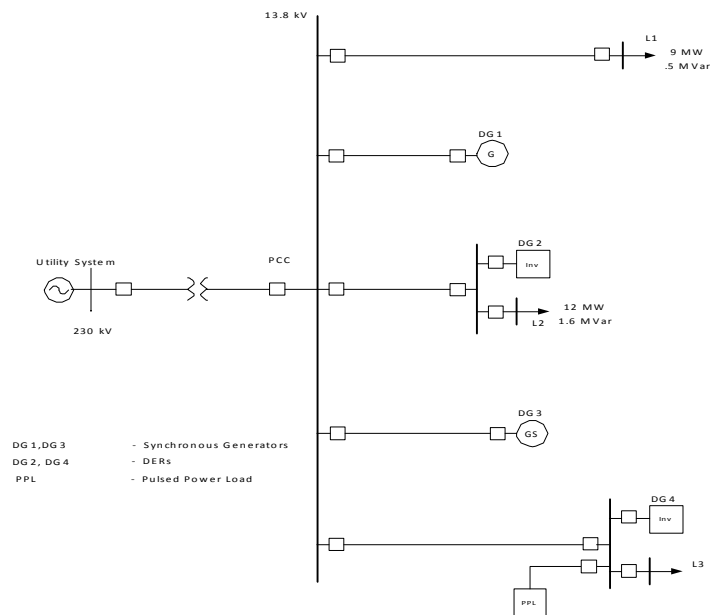

**Figure 6. Study Microgrid System in Task 3**

PPL can be connected to a microgrid either directly or through a storage element. For the proposed work PPL connected through a capacitor is considered since the system is unable to provide the peak load of the PPL without losing stability. The PPL model consists of a three phase rectifier, filter circuit and buck converter.

#### Publications & Conferences

- L. Piyasinghe, and Z. Miao, “Investigation of the Microgrid Operation with Pulsed Power Loads,” Technology and Innovation (accepted).