

*Design, Construction and Operation of CSP Solar Thermal Power Plants in Florida*  
(Progress Report)

**PI:** D. Yogi Goswami **Co-PIs:** Elias Stefanakos, Muhammad M. Rahman, Sunol Aydin, Robert Reedy  
**Students:** Gokmen Demirkaya (Ph.D.); Ricardo Vasquez Padilla (Ph.D.); Huijuan Chen (Ph.D.); Jamie Trahan (Ph.D.)

**Description:**

Florida utilities are mandated to achieve 20% renewable energy contribution to their generation mix by 2020. While technologically feasible with solar energy, the capital costs are high – presently, capital costs range from \$6,000-\$7,000/kW for PV and \$3,500-\$4,000/kW for concentrating solar thermal power. This project targets the development of solar thermal power technology for bulk power and distributed generation, which will diversify energy resources in Florida and reduce greenhouse emissions by utilizing renewable sources. Also, there will be economic impacts with the establishment of new power industry in Florida, which will help the electrical utilities of the state to meet the renewable portfolio standards. The project has three main tasks; the first one is to develop design methodologies and standards for the proven solar thermal power technologies in combination with bio or fossil fuels based on Florida conditions and resources. Secondly, the project aims to set up demonstration and test facilities for these technologies for optimization for Florida conditions, and the final task is to develop and commercialize innovative technologies based on new thermodynamic cycles.

FIG. 1 DIRECT NORMAL RADIATION FOR TAMPA, FL

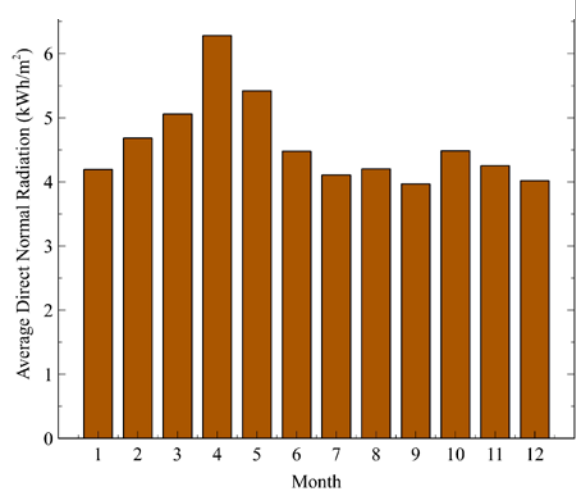

**Budget:** \$882,000

**Universities:** USF, UF, UCF

**External Collaborators:** Sopogy Corporation

**Progress Summary**

**Research Objectives for Current Reporting Period:**

The main research objectives for the current reporting period include the development of a test facility and pilot demonstration systems based on parabolic trough technology.

**Progress Made Toward Objectives during Reporting Period**

Daily integration (DI) approach was used to obtain the average direct normal solar radiation for the location of the pilot demonstration solar plant (USF, Tampa, FL). The direct normal solar radiation obtained for Tampa is shown in Fig. 1. The annual average for this location is 4.6 kWh/m<sup>2</sup>-day. These solar radiation values and the solar shading analysis for solar collector rows were used for the solar field calculation. Picture in Fig. 2 show status on the installation of 50kWe solar power system. The Soponova 4.0 (Sopogy Inc.) parabolic trough collectors will be used in the solar field for providing 430 W/m<sup>2</sup> of

thermal energy after losses. The solar field is being designed to work in conjunction with a thermal energy storage system which will use phase change material (PCM) as a storage material.

The remaining thermal energy will be provided by a natural gas boiler, which will work in series with the solar field and supply thermal energy to the power block when the solar energy is not available.

The power block that will convert the thermal energy to electricity is based on Organic Rankine Cycle. This power block will have a nominal capacity of 50 kW<sub>e</sub>. A preliminary study on condensation methods for solar thermal plants is also conducted and more research will be devoted to the development of cost effective dry cooling technology.



Fig.2. Solar Field for 50 kWe power generation

The following describes a summary of the background research that was needed to move forward with the design and construction of the power plant.

### Parabolic Trough Concentrators

The performance of parabolic trough based solar power plants over the last 25 years has proven that this technology is an excellent alternative for the commercial power industry. Compared to conventional power plants, parabolic trough solar power plants produce significantly lower levels of carbon dioxide, although additional research is required to bring the cost of concentrator solar plants to a competitive level. The cost reduction is focused on three areas: thermodynamic efficiency improvements by research and development, scaling up of the unit size, and mass production of the equipment. The optimum design, performance simulation and cost analysis of the parabolic trough solar plants are essential for the successful implementation of this technology. A detailed solar power plant simulation and analysis of its components is needed for the design of parabolic trough solar systems which is the subject of this research.

Preliminary analysis was carried out by complex models of the solar field components. These components were then integrated into the system whose performance is simulated to emulate real operating conditions. Sensitivity analysis was conducted to get the optimum conditions and minimum levelized cost of electricity (LCOE). A simplified methodology was then developed based on correlations obtained from the detailed component simulations.



Florida Energy Systems Consortium

A comprehensive numerical simulation of a parabolic trough solar power plant was developed, focusing primarily on obtaining a preliminary optimum design through the simplified methodology developed in this research. The proposed methodology is used to obtain optimum parameters and conditions such as: solar field size, operating conditions, parasitic losses, initial investment and LCOE. The methodology is also used to evaluate different scenarios and conditions of operation.

The new methodology was implemented for a parabolic trough solar power plant for two cities: Tampa and Daggett. The results obtained for the proposed methodology were compared to another physical model (System Advisor Model, SAM) and a good agreement was achieved, thus showing that this methodology is suitable for any location.

### Power Cycles for Solar Thermal Power

Low-grade heat sources below 300°C, are abundantly available as industrial waste heat, solar thermal using low cost solar concentrators, and geothermal, to name a few. However, they are under-exploited for conversion to power because of the low efficiency of conversion. The utilization of low-grade heat is advantageous for many reasons. Technologies that allow the efficient conversion of low-grade heat into mechanical or electrical power are very important to develop.

Supercritical Rankine cycles were investigated for the conversion of low-grade heat into power. The performance of these cycles was studied using ChemCAD linked with customized excel macros written in Visual Basic and programs written in C++.

The selection of working fluids for a supercritical Rankine cycle is of key importance. A rigorous investigation into the potential working fluids was carried out, and more than 30 substances were screened out from all the available fluid candidates. Zeotropic mixtures were proposed to be used in supercritical Rankine cycles to improve the system efficiency. Supercritical Rankine cycles and organic Rankine cycles with pure working fluids as well as zeotropic mixtures were optimized for efficient conversion of low-grade heat into power. The results show that it is theoretically possible to extract and convert more energy from such heat sources using the cycle developed in this research than the conventional organic Rankine cycles. A theory on the selection of appropriate working fluids for different heat source and heat sink profiles was developed to customize and maximize the thermodynamic cycle performance.

The outcomes of this research will eventually contribute to the utilization of low-grade waste heat more efficiently.

### Combined Power/Cooling Cycle

Binary mixtures exhibit variable boiling temperatures during the boiling process, which leads to a good thermal match between the heating fluid and working fluid for efficient heat source utilization. This study presents a theoretical and an experimental analysis of a combined power/cooling cycle, which combines the Rankine power cycle and the absorption refrigeration cycle to produce power and refrigeration in the same cycle, while power is the primary goal. This cycle, also known as the *Goswami Cycle*, can be used as a bottoming cycle to utilize the waste heat from a conventional power cycle or as an independent cycle using low to mid-temperature sources such as geothermal and solar energy. A thermodynamic analysis of power and cooling cogeneration was conducted. The performance of the cycle for a range of boiler pressures, ammonia concentrations, and isentropic turbine efficiencies were studied to find out the sensitivities of net work, amount of cooling and effective efficiencies. The thermodynamic analysis covered a broad range of boiler temperatures, from 85 °C to 350 °C. The first law efficiencies of 25-31%

are achievable with the boiler temperatures of 250-350 °C. The cycle can operate at an effective exergy efficiency of 60-68% with the boiler temperature range of 200-350 °C. An experimental study was conducted to verify the predicted trends and to test the performance of a scroll type expander. The experimental results of vapor production were verified by the expected trends to some degree, due to heat transfer losses in the separator vessel. The scroll expander isentropic efficiency was between 30-50%, the expander performed better when the vapor was superheated. The small scale of the experimental cycle affected the testing conditions and cycle outputs. This cycle can be designed and scaled from a kilowatt to megawatt systems. Utilization of low temperature sources and heat recovery is definitely an active step in improving the overall energy conversion efficiency and decreasing the capital cost of energy per unit.

Task 1: Development of simulation and design methodology for parabolic trough and parabolic dish  
 The objective of the task one is to develop a simulation and design methodology for the parabolic trough and parabolic dish based technologies for Florida conditions. Solar radiation, solar collector and thermal storage topics are the subtasks, and following progresses have been made during the period.

Parabolic trough solar systems are currently one of the most mature and prominent applications of solar energy for production of electricity.

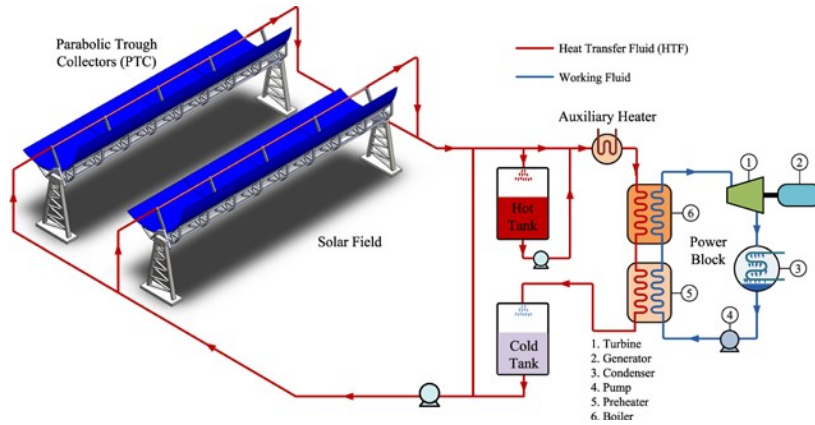

FIG. 4 PARABOLIC TROUGH POWER PLANT

Compared to conventional power plants, parabolic trough solar power plants produce significantly lower levels of emissions and carbon dioxide. Thermal simulations and cost analysis of the system are used to evaluate the economic feasibility. Complex models and components are integrated to emulate real operating conditions, such as: Solar Radiation Model, Solar Thermal

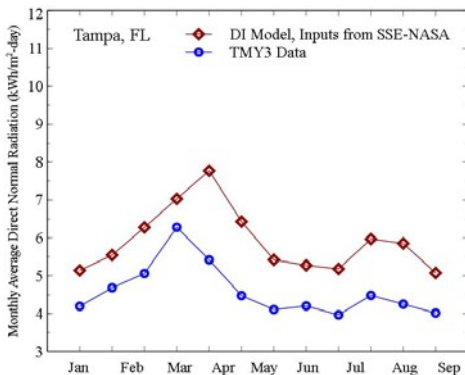

FIG. 3 COMPARISON OF TWO

meteorological conditions in locations where ground measurement data are not available. Gueymard developed a Daily integration approach model to predict the monthly-average hourly global irradiation by using a large dataset of 135 stations with diverse geographic locations (82.58N to 67.68S) and climates. The results showed that the daily integration model is most accurate than previous hourly models.

Collector, Thermal Energy Storage, Solar Field Piping, Power Block, Cost Analysis, and Integration of all Systems. This progress report presents a preliminary design method to calculate solar radiation data and thermal collector efficiency which are used to determine the size and the cost of solar field.

An hourly solar radiation model is necessary to calculate the energy input that come from the sun, since the solar collector performance changes during the whole day. The inputs for the hourly solar radiation model are the long term average values of total horizontal and diffuse radiation, which can be obtained by ground or satellite measurements. Satellite data provide information about solar radiation and



The second part of this report is about the numerical heat transfer model. The receiver consists of an absorber surrounded by a glass envelope. The absorber is typically stainless steel tube with a selective absorber surface. The glass envelope is an antireflective evacuated glass tube which protects the absorber from degradation and reduces heat losses. The Solar receiver uses conventional glass to metal seals and bellows to achieve the necessary vacuum enclosure and for thermal expansion.

The heat transfer model is based on an energy balance between the heat transfer fluid and the surroundings (atmosphere and sky). A comprehensive radiation model between the absorber and the envelope is included in this study. The results showed that the new model has lower RMSE than the NREL Model (0.985% and 1.382% respectively). The numerical heat transfer model integrated with the solar radiation model can be used for evaluating the performance of solar collectors for any location.

### Task 2: Development of a test facility and pilot demonstration

The second task targets the development of a test facility and pilot demonstration systems based on parabolic trough and dish technologies. The experimental combined power and cooling setup will be used as a preliminary study of the demonstration system that will be developed.

#### 2.1 PERFORMANCE ANALYSIS OF A RANKINE-GOSWAMI COMBINED CYCLE

Improving the efficiency of thermodynamic cycles plays a fundamental role for the development of solar power plants. These plants work normally with Rankine cycles which present some disadvantages due to the thermodynamic behavior of steam at low pressures. These disadvantages can be reduced by introducing alternatives such as combined cycles which combine the best features of each cycle. In the present study a combined Rankine-Goswami cycle is proposed and a thermodynamic analysis is conducted. The Goswami cycle, used as a bottoming cycle, uses ammonia-water mixture as the working fluid and produces power and refrigeration while power is the primary goal. Figure 5 shows a schematic of the Rankine-Goswami cycle.

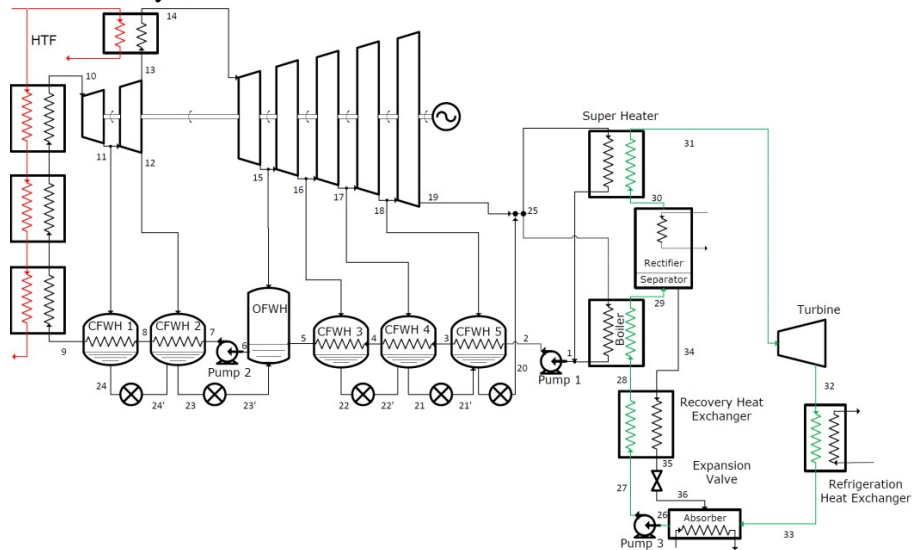

Fig.5

The detailed explanation about the parameters that were used for simulation is given in the paper. Different cases were also considered for parametric studies which are shown below.

Case	Rectifier	Superheater	Controlled Parameter
R	Yes	No	$x_{rectifier} = 0.995$ $T_{superheater} = T_{rectifier}$
R+S	Yes	Yes	$x_{rectifier} = 0.98$ $T_{superheater} = T_{boiler}$
B (Base)	No	No	Saturated vapor condition at the boiler exit

The thermodynamic properties of water and steam were implemented in Python 2.6 by using the international-standard IAPWS-IF97 steam tables. For the Goswami cycle, the properties of ammonia water were obtained from a Gibbs free energy formulation given by Xu and Goswami. In this study the amount of the electric work obtained from the topping cycle was held constant at 50 MWe while for the bottoming cycle the turbine work was considered as an output parameter. Figure 6 shows the effect of the high pressure side on the rectifier temperature and absorber concentration, In this case, the ammonia concentration range was selected such as the absorber was kept at least under atmospheric pressure.

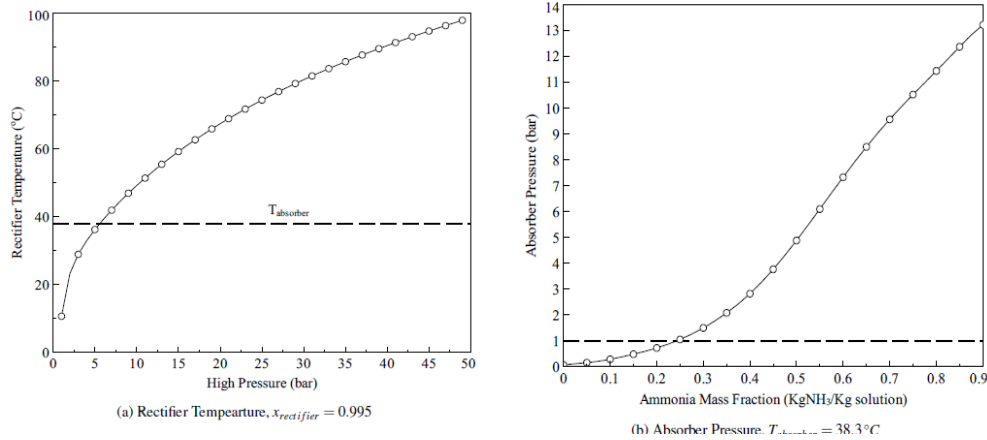

Fig 6

Figure 7 shows the effect of the condenser pressure on the Goswami bottoming cycle exit quality for different cases and ammonia mass fraction. Moreover, Figure 8 shows the effect of the variations of the net -work with the condenser pressure for ammonia mass concentration of 0.3, in all the studied cases.

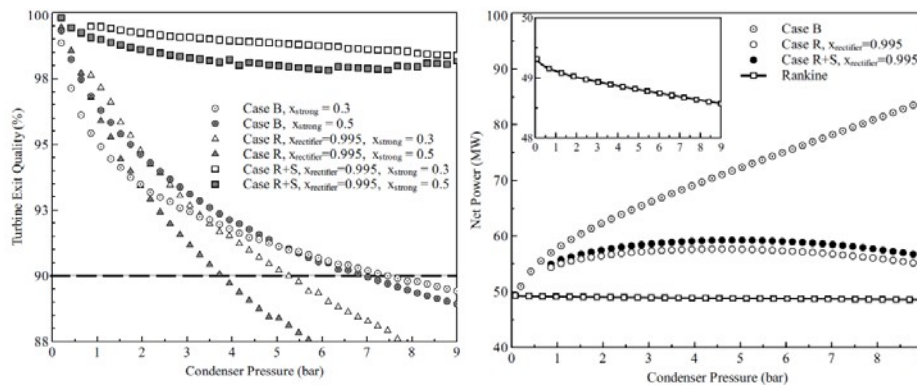

Fig.7

Fig. 8

The effect of condenser pressure on the effective First Law efficiency is also illustrated in Figure 9 while the cooling capacity of the Goswami bottoming cycle is presented in Figure 10. The effective exergy efficiency in the cycle as a function of the condenser pressure and ammonia mass fraction is also presented in Fig.11.

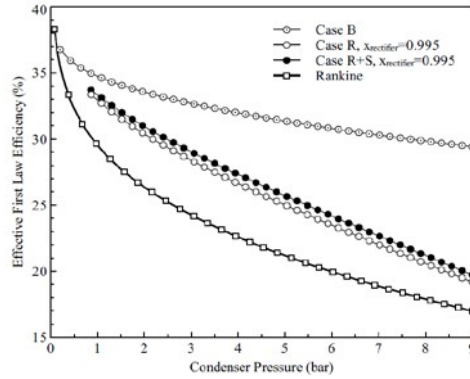

Fig. 9

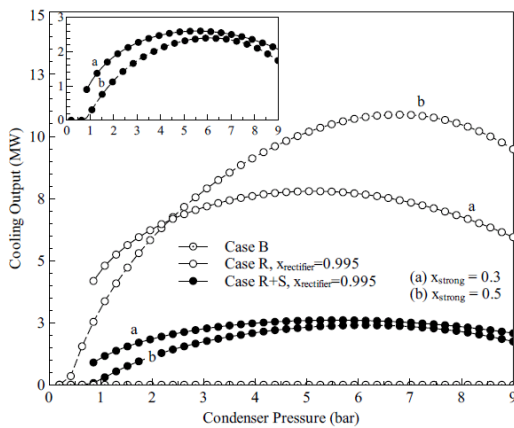

Fig. 10

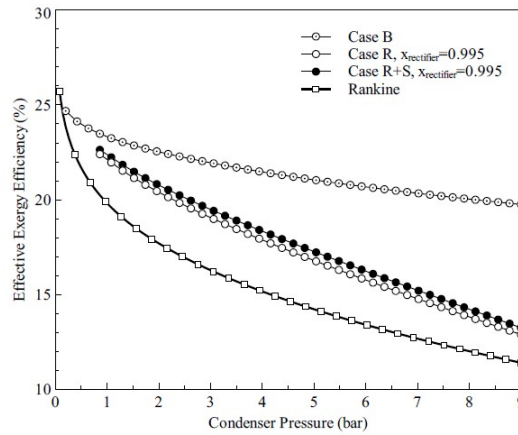

Fig. 11

### Task 3. Installation and Operation of 50kWe Solar Power Plant

Sopogy Inc. Honolulu, Hawaii is the main contractor for installation and operation of 50kWe Solar Power Plant at USF. Parabolic collectors (Soponova 4.0) were received from Sopogy and were assembled. Power block for generating electricity from GulfCoast Green Energy was also received. Power block is a Green Machine Elite 4000 manufactured by Electratherm. This machine will produce about 50kWh electricity from the thermal energy produces by solar field that will have 199 Soponova 4.0 parabolic concentrators from Sopogy Inc. Concrete foundation for installation of collectors is complete (see picture as shown in Fig. 2). Work will soon start to install collectors on the concrete foundations and complete installation of other parts.

### Task 4: Thermal Energy Storage

We are currently working on the development of low cost thermal energy storage (TES) systems for Concentrating Solar Power (CSP). The objective is to research and develop a thermal energy storage system (operating range 300<sup>0</sup>C – 450 <sup>0</sup>C) based on encapsulated phase change materials (PCMs). The system will be able to meet the utility-scale base-load concentrated solar power plant requirements at much lower system costs compared to the existing TES concepts. This project is developing a TES system concept that will allow for an increase of the capacity factor of the present CSP technologies to 75% or greater and reduce the cost to less than \$10/kWh<sub>th</sub> as compared to the present cost of about \$40/kWh<sub>th</sub>.

We have successfully prepared porous pellets of phase change materials that will allow for the volumetric expansion during PCM melting and hence impose less stress on the encapsulating material. We have developed the encapsulation techniques and selected the low cost encapsulating materials that will be



used to encapsulate the PCM. Currently we are optimizing the process for encapsulating the PCMs for various salts and salt eutectics in the temperature range from 300 to 1000<sup>0</sup>C.

## Publications

1. Besarati, S.M., Vasquez Padilla, R., Goswami, D.Y., and Stefanakos, E. (2013) "The potential of harnessing solar radiation in Iran: Generating solar maps and viability study of PV power plants," *Renewable Energy*, 53, pp. 193-199.
2. Chen, H. and Goswami D.Y. (2008) "The conversion of moderate temperature heat into power and refrigeration," in the Proceedings of the Annual Meeting of the American Institute of Chemical Engineers, Philadelphia, November.
3. Chen, H. and Goswami D.Y. (2009) "The conversion of moderate temperature heat into power and refrigeration with CO<sub>2</sub> and organic binary working fluid, in the Proceedings of biennial international student conference of Education without Borders", Dubai, UAE, March-April.
4. Chen, H. and Goswami D.Y. (2010) "Converting Low-Grade heat into Power using a Supercritical Rankine cycle with Zeotropic Mixture Working Fluid," in the Proceedings of ASME 2010 4th International Conference on Energy Sustainability, Phoenix, Arizona May.
5. Chen, H., and Goswami, Y. (2008) "Simulation of a Thermodynamic cycle with Organic Absorbents and CO<sub>2</sub> as Working fluids," in the Proceedings of the ASME 3rd International Conference on Energy Sustainability, Jacksonville, FL, August.
6. Chen, H., Goswami, D. Yogi, Rahman, M.M., and Stefanakos, E.K. (2011) "A supercritical Rankine cycle using zeotropic mixture working fluids for the conversion of low-grade heat into power," *Energy*, vol. 36 (1), pp. 549-555.
7. Chen, H., Goswami, D.Y., and Stefanakos, E.K. (2010) "A Review of Thermodynamic Cycles and Working Fluids for the Conversion of Low-Grade Heat," *Renewable and Sustainable Energy Reviews*, 14 (9), 3059-3067.
8. Chen, H., Goswami, D.Y., Rahman, M.M., and Stefanakos, E.K. (2011) "Energetic and Exergetic analysis of CO<sub>2</sub>- and R32-based Transcritical Rankine Cycles for Low-Grade Heat Conversion," *Applied Energy*, 88, pp. 2802-2808.
9. Chen, H., M.M. Rahman, D.Y. Goswami, E.K. Stefanakos (2011) "Optimizing energy conversion using organic Rankine cycles and supercritical Rankine cycles," in the Proceedings of the Proceedings of the ASME ESFuelCell 2011 Conference, Washington, D.C., August.
10. Demikaya, G., Vasquez Padilla, R., and Goswami, D.Y. (2013) "A review of combined power and cooling cycles," *WIRES Energy Environ* 2013. Doi: 10.1002/wene.75
11. Demirkaya, G., Besarati, S., Vasquez Padilla, R., Ramos Archibold, A., Goswami, D.Y., Rahman, M.M., Stefanakos, E.K. (2012) "Multi-objective optimization of a combined power and cooling cycle for low-grade and mid-grade heat sources," *Journal of Energy Resources Technology (ASME)*, 134, 032002-1.
12. Demirkaya, G., Besarati, S.M., Vasquez Padilla, R., Ramos, A.A., Rahman, M.M., Goswami, D.Y., and Stefanaksos, E. (2011) "Multi-Objective Optimization of a Combined Power and Cooling Cycle for Low-Grade and Mid-Grade Heat Sources," in the Proceedings of the ASME ESFuelCell 2011 Conference, Washington, D.C., August.
13. Demirkaya, G., Padilla, R.V., Goswami, D.Y., Stefanakos, E., Rahman, M.M. (2011) "Analysis of a combined power and cooling cycle for low-grade heat sources," *International Journal of Energy Research*, 35 (13), pp. 1145-1157.
14. Goswami, D.Y. "Keynote address: Emerging CSP Market in India," SolarPACES conference, Berlin, Germany, September 2009.
15. Li, C., Besarati, S., Goswami, Y., Stefanakos E., and Chen, H. (2012) "Reverse osmosis desalination driven by low temperature supercritical organic rankine cycle," (pre press accepted and available online, October 2012) *Applied Energy*.



16. Li, C., Besarati, S., Goswami, Y., Stefanakos, E., and Chen, H. (2013). "Reverse osmosis desalination driven by low temperature supercritical organic rankine cycle," *Applied Energy*, 102, pp. 1071-1080.
17. Padilla, R. V., Ramos, A.A., Demirkaya, G., Besarati, S., Goswami, D.Y., Rahman, M.M., and Stefanakos, E.K. (2011) "Performance Analysis of a Rankine-Goswami Combined Cycle," Proceedings of the ASME 2011 "ESFuelCell 2011" (5<sup>th</sup> International Conference on Energy Sustainability and 9<sup>th</sup> Fuel Cell Science Engineering and Conference), Washington, DC, August.
18. Padilla, R.V., Demirkaya, G., Goswami, D.Y., Stefanakos, E., and Rahman, M.M. (2011) "Heat transfer analysis of parabolic trough solar receiver," *Applied Energy*, Vol. 88 (12), pp. 5097-5110.
19. Padilla, R.V., Demirkaya, G., Goswami, D.Y., Stefanakos, E., and Rahman, M.M. (2010) "Analysis of power and cooling cogeneration using ammonia-water mixture," *Energy*, Vol. 35 (12), pp. 4649-4657.
20. Padilla, R.V., Demirkaya, G., Goswami, Y., and Stefanakos, E.K. (2010) "Parametric study of a combined power and cooling thermodynamic cycle for low temperature sources," in the Proceedings of the 2010 ASME International Mechanical Engineering Congress and Exposition, 6, pp. 165-174.
21. Vasquez Padilla, R., Demirkaya, G., and Goswami, D.Y. (2009) "Parametric Study of a Combined Power and Cooling Thermodynamic Cycle for Low Temperature Heat Sources," in the Proceedings of the 2009 ASME International Mechanical Engineering Congress and Exposition Conference (IMEC-E 2009), Lake Buena Vista, FL, November.
22. Vasquez Padilla, R., Ramos Archibold, A., Demirkaya, G., Besarati, S., Goswami D.Y., Rahman, M.M., and Stefanakos, E.K. (2012) "Performance analysis of a rankine cycle integrated with the Goswami combined power and cooling cycle." *Journal of Energy Resources Technology*, 134, 032001-1.
23. Vidhi, R., Goswami, D.Y., Chen, H., Stefanakos, E., and Kuravi, S. (2011) "Study of supercritical carbon dioxide power cycle for low grade heat conversion," Proceedings of the Supercritical CO<sub>2</sub> Power Cycle Symposium, Denver, Colorado, May.

## Current and Pending Support

4/18/2013

Investigator: Goswami, Dharendra Yogi

**Support:** Current **Role:** PI

**Title:** Performance Evaluation Energy Saving Potential of VaporGenics Organic Rankine Cycle Ait-Conditioning Unit

**Source of Support:** Florida Power and Light Company

**Total Award Amount:** \$113,516 **Award Period:** 12/1/2012 to 12/31/2013

**Location of Project:** University of South Florida, Tampa, FL

**Person-Months per year Committed:** 1.00 **Type:** Sum

Award ID	21311019	Proposal ID	130000547	Proposal Date	10/26/2012
----------	----------	-------------	-----------	---------------	------------

**Support:** Current **Role:** PI

**Title:** Innovative Latent Thermal Energy Storage System for Concentrating Solar Power Plants

**Source of Support:** E-ON, International

**Total Award Amount:** \$646,359 **Award Period:** 1/1/2011 to 12/31/2013

**Location of Project:** University of South Florida, Tampa, FL

**Person-Months per year Committed:** 0.50 **Type:** Sum

Award ID	21311009	Proposal ID	100001206	Proposal Date	03/10/2010
----------	----------	-------------	-----------	---------------	------------

**Support:** Current **Role:** PI

**Title:** Development of a Low Cost Thermal Energy Storage System Using Phase Change Materials with Enhanced Radiation Heat Transfer (Adv. Research Proj. Agcy-Energy)

**Source of Support:** Department of Energy

**Total Award Amount:** \$1,523,872 **Award Period:** 12/5/2011 to 12/4/2014

**Location of Project:** University of South Florida, Tampa, FL

**Person-Months per year Committed:** 0.75 **Type:** Sum

Award ID	21311015	Proposal ID	110001529	Proposal Date	05/19/2011
----------	----------	-------------	-----------	---------------	------------

Investigator: Goswami, Dharendra Yogi	
Support: Current	Role: PI
Title: Development and Demonstration of an Innovative Thermal Energy Storage System for Baseload Power Generation	
Source of Support Department of Energy	
Total Award Amount	\$769,286 Award Period: 8/1/2010 to 7/31/2014
Location of Project: University of South Florida, Tampa, FL	
Person-Months per year Committed: 1.00 Type: Sum	
Award ID	21311007 Proposal ID 10000475 Proposal Date 10/19/2009
Support: Current	
Role: Co-PI	
Title: Removal of Off-Flavor Compounds in Aquaculture Food Products: Optimizing New Techniques for Sustainable Aquaculture Systems	
Source of Support Florida Aquaculture Review Council	
Total Award Amount	\$114,714 Award Period: 7/1/2012 to 6/30/2013
Location of Project: University of South Florida, Tampa, FL	
Person-Months per year Committed: 0.25 Type: Sum	
Award ID	21071068 Proposal ID 110001120 Proposal Date 05/13/2010
Support: Current	
Role: Co-PI	
Title: Linear-Focus Concentrating Solar Collector Based on a Novel Receptor-Development and Demonstration	
Source of Support NCSR Demokritos	
Total Award Amount	\$19,212 Award Period: 2/1/2013 to 1/31/2015
Location of Project: University of South Florida, Tampa, FL	
Person-Months per year Committed: 0.10 Type: Sum	
Award ID	21311018 Proposal ID 130001030 Proposal Date
Support: Pending	
Role: PI	
Title: Solar Energy Research Institute for India and the United States	
Source of Support National Renewable Energy Lab	
Total Award Amount	\$252,002 Award Period: 1/1/2012 to 12/31/2016
Location of Project: University of South Florida, Tampa, FL	
Person-Months per year Committed: Type:	
Award ID	Proposal ID 120000218 Proposal Date 08/04/2011

Investigator: Goswami, Dharendra Yogi				
Support: Pending		Role: PI		
Title: Innovative High Efficiency High Temperature Combines Cycle Power Generation				
Source of Support		Department of Energy		
Total Award Amount	\$934,301	Award Period:	7/1/2012 to	6/30/2015
Location of Project: University of South Florida, Tampa, FL				
Person-Months per year Committed:		1.00	Type:	Sum
Award ID	Proposal ID	120001165	Proposal Date	02/06/2012
Support: Pending				
		Role: PI		
Title: Field Testing of Gas Heat Pump				
Source of Support		Associated Gas Distributors of Florida		
Total Award Amount	\$199,966	Award Period:	7/1/2012 to	6/30/2013
Location of Project: University of South Florida, Tampa, FL				
Person-Months per year Committed:		0.20	Type:	Sum
Award ID	Proposal ID	120001688	Proposal Date	05/24/2012
Support: Pending				
		Role: PI		
Title: Field Testing of Gas Heat Pump				
Source of Support		Associated Gas Distributors of Florida		
Total Award Amount	\$199,966	Award Period:	7/1/2012 to	6/30/2013
Location of Project: University of South Florida, Tampa, FL				
Person-Months per year Committed:		0.20	Type:	Sum
Award ID	Proposal ID	130000396	Proposal Date	05/24/2012
Support: Pending				
		Role: PI		
Title: Evaluation of VaporGenics Air Conditioning Unit using Natural Gas Technology				
Source of Support		Associated Gas Distributors of Florida		
Total Award Amount	\$50,000	Award Period:	2/1/2013 to	1/1/2014
Location of Project: University of South Florida, Tampa, FL				
Person-Months per year Committed:		0.10	Type:	Sum
Award ID	Proposal ID	130001135	Proposal Date	03/04/2013



Investigator: Goswami, Dharendra Yogi				
Support: Pending		Role: PI		
Title: MRI: Development of An Automated Engineering Test Bench to Support Research and Training of Terahertz Devices				
Source of Support National Science Foundation				
Total Award Amount \$506,032		Award Period: 8/1/2011 to 7/31/2014		
Location of Project: University of South Florida, Tampa, FL				
Person-Months per year Committed:		Type: Sum		
Award ID	Proposal ID	110001078	Proposal Date	
Support: Pending				
Role: PI				
Title: Hydrogen rich gas production from Supercritical Gasification of Biomass				
Source of Support U.S.-Egypt Science & Technology Joint Fund				
Total Award Amount \$67,501		Award Period: 1/3/2012 to 1/3/2015		
Location of Project: University of South Florida, Tampa, FL				
Person-Months per year Committed:		Type: Sum		
Award ID	Proposal ID	120000867	Proposal Date	
Support: Pending				
Role: Co-PI				
Title: Novel Chromism in Nanocomposite Materials for Energy Saving Applications				
Source of Support National Science Foundation				
Total Award Amount \$429,415		Award Period: 7/1/2013 to 6/30/2016		
Location of Project: University of South Florida, Tampa, FL				
Person-Months per year Committed: 0.30		Type: Sum		
Award ID	Proposal ID	130001020	Proposal Date	02/12/2013
Support: Pending				
Role: Co-PI				
Title: High Energy Density supercapacitors based on novel materials and fabrication techniques				
Source of Support National Science Foundation				
Total Award Amount \$313,766		Award Period: 7/1/2013 to 6/30/2016		
Location of Project: University of South Florida, Tampa, FL				
Person-Months per year Committed: 0.10		Type: Sum		
Award ID	Proposal ID	130001059	Proposal Date	02/20/2013

Investigator: Goswami, Dharendra Yogi				
Support: Pending		Role: Co-PI		
Title: Production of synthetic Crude from biomass via thermochemical conversion: An integrated cradle to grave approach				
Source of Support		Department of Energy		
Total Award Amount	\$3,500,000	Award Period:	6/1/2013 to	5/31/2016
Location of Project:		University of South Florida, Tampa, FL		
Person-Months per year Committed:		Type:		
Award ID	Proposal ID	120001504	Proposal Date	04/17/2012
<hr/>				
Support: Pending		Role: Co-PI		
Title: Innovative High Efficiency, High Temperature Combined Cycle Power Generation				
Source of Support		Department of Energy		
Total Award Amount	\$900,000	Award Period:	7/1/2012 to	6/30/2015
Location of Project:		University of South Florida, Tampa, FL		
Person-Months per year Committed:		Type: Sum		
Award ID	Proposal ID	120000774	Proposal Date	11/22/2011
<hr/>				
Support: Pending		Role: Co-PI		
Title: SusChEM/GOAL: Removing off-flavor compounds from food-fish production through sustainable technologies				
Source of Support		National Science Foundation		
Total Award Amount	\$600,001	Award Period:	8/15/2013 to	8/24/2016
Location of Project:		University of South Florida, Tampa, FL		
Person-Months per year Committed:		0.20 Type: Sum		
Award ID	Proposal ID	130001066	Proposal Date	02/19/2013
<hr/>				
Support: Pending		Role: Co-PI		
Title: Production of Synthetic Crude Biomass via Thermochemical Conversion: An Integrated Cradle to Grave Approach				
Source of Support		Department of Education		
Total Award Amount	\$4,816,895	Award Period:	1/1/2013 to	12/31/2016
Location of Project:		University of South Florida, Tampa, FL		
Person-Months per year Committed:		3.00 Type:		
Award ID	Proposal ID	130000174	Proposal Date	04/17/2012